

Ambient Light Sensor (ISL29023) Opto-Mechanical Reference Design

Introduction

Ambient Light Sensors have become widely established components in digital display products. Virtually every contemporary flat display, regardless of backlighting approach, implements ambient light sensing to facilitate display brightness control. While dynamic display brightness control improves display viewability and reduces user eye-strain, more significantly it enables extended battery operational life in mobile devices.

The ambient light sensing function may be implemented using discrete components, such as silicon photodetectors and transimpedance (current-to-voltage) amplifiers. However, fully integrated, mixed-signal sensor devices are more common in backlit digital displays. Many ambient light sensors work quite well, others do not. However, more often than not, it is not the sensor device that performs inadequately; it is the optical/mechanical implementation in the display product that is at fault.

An ambient light sensor is an opto-electronic device - it has two separate but, equally important interfaces: electrical and optical. Inattention to either interface will reduce performance and possibly lead to functional failure under certain conditions. Just as device functionality depends on proper electrical connections and signal characteristics, the sensor also must be provided with proper optical paths and optical signals. It is through the optical/mechanical product design that proper optical signal paths and signal integrity are implemented.

Typically, product designers do not want the user to be aware of the ambient light sensor or its location, during normal use. Therefore, the sensor frequently is located under heavily tinted glass - allowing only a small fraction (5% to 10%) of ambient illumination to reach the sensor. Additionally, ambient illumination may be able to reach the sensor only through a small aperture or, window in the product case. This aperture may reduce the quantity of ambient illumination at the sensor. But, more importantly, it may reduce the sensor Field-of-View - the viewing angle range over which unobscured ambient illumination reaches the sensor.

This Application Note provides valuable optical/mechanical guidelines and insights for best performance for Intersil Ambient Light Sensor products. One of the most frequently used Intersil products, the ISL29023, is chosen to demonstrate the design concepts in the following examples.

Contents

- Introduction 1**
- Ambient Light Sensor Field-of-View 1**
- The General Opto-Mechanical Reference Model 2**
- Window Materials 3**
- The Circular Aperture Model 4**
- Hard Aperture vs Soft Aperture 5**
- Appendix A: Solid-Angle Geometry 6**
- Appendix B: Radiometry and Photometry 8**
- Bibliography 9**

Ambient Light Sensor Field-of-View

The Ambient Light Sensor Field-of-View (FOV) - typically expressed as $\pm\theta$ in degrees - is a critical parameter in the performance of the sensor device. A large FOV allows the sensor to integrate the illuminance over a large area, possibly including several ambient light sources or luminaires. This eliminates sensor directionality that could cause undesirable changes in display brightness due to sensor shadowing by the consumer. For example, consider a sensor with a $\pm 12.5^\circ$ FOV located in the upper frame of a desktop flat-panel monitor. At a distance of $\sim \frac{1}{2}$ meter from the monitor (typical viewing distance), the FOV span (width in space) will be ~ 20 cm - the width of a typical human head. If the primary luminaire is directly behind the consumer when s/he sits in front of the monitor, the consumer's head may completely shadow the sensor - thus, causing a change in the display brightness. This is not a desirable situation. However, if the sensor FOV is more like $\pm 35^\circ$, the consumer's head will subtend a solid-angle of ~ 0.15 sr, obscuring only 13% of the sensor FOV.

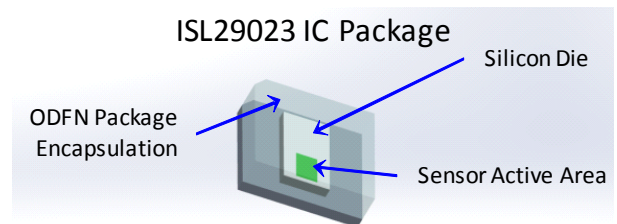

FIGURE 1. THE ISL 29023 IC PACKAGE

Application Note 1782

The sensor intrinsic FOV is defined by the angular sensitivity of the silicon photo-sensor, the geometry of the photo-sensor and the thickness and refractive index of the ODFN (Optical Dual Flat No-lead) package encapsulation. Since the ISL29023 photo-sensor is rectangular, as shown by Figure 1, the intrinsic FOV in air will have a rectangular cross-section, or pyramidal, rather than conical, shape. Thus, best illumination over the ambient FOV will be obtained using a rectangular window as shown in Figure 2. While the ISL29023 intrinsic FOV typically is $\pm 55^\circ$, the window shown in Figure 2 provides for an Ambient FOV of $\pm 35^\circ$, as recommended in previous.

The General Opto-Mechanical Reference Model

The ISL29023 Opto-Mechanical Reference Model is shown in Figure 2, illustrating the FOV, and in Figure 3, showing the principle components and dimensions. The Model consists of the ISL29023 IC package mounted to a PC board (typically, a Flex-PCB) spaced 3.0mm below a 0.7mm - thick glass Window mounted in a non-transmitting Cover Frame, or Case. The specified dimensions are typical when the ISL29023 is used in mobile consumer products with back-lit flat displays. Typically, the Frame also includes structural members that set the PCB spacing and also provide some optical isolation for the Ambient Light Sensor, ISL29023.

The glass Window is rectangular to provide best FOV for illumination of the ISL29023 photo-sensor. As shown in Figure 1, the ISL29023 photo-sensor active area is not centered in the IC package, rather offset toward one end. The Window should be centered over the Sensor active area, rather than the IC package for best performance. This provides symmetric FOV in all directions.

The Window size is defined by the desired FOV to $\pm 35^\circ$ in Figure 2 and the PCB-to-Window separation 3mm in Figure 3. Figure 4 shows the Reference Model in side view. Determination of the optimal window dimensions is a matter of simple geometry. The following steps illustrate a typical approach:

1. Select the PCB-to-Window separation distance - 3.0mm as shown in Figure 4.
2. Select the desired Field-of-View for the Ambient Light Sensor to $\pm 35^\circ$ in the Figure 4 example.
3. Determine the full Aperture-to-Sensor distance:

$$T = \text{Gap} + t_w - s_v \quad (\text{EQ. 1})$$

where Gap is the PCB-to-Window Distance, 3.0mm, t_w is Window thickness, 0.7mm, and s_v is the vertical sensor location relative to the ISL29023 IC package, 0.4mm.

4. Calculate the Window dimension:

$$\text{Win} = 2 \cdot T \cdot \tan 35^\circ + s_w \quad (\text{EQ. 2})$$

where T is the full Aperture-to-Sensor distance, and s_w is the ISL29023 sensor width, 0.49mm.

5. Adjust for the Window Material Refractive Index:

$$\Delta \text{Win} = 2 \cdot t_w \cdot \left(\tan 35^\circ - \tan \left(\frac{1}{n} \cdot 35^\circ \right) \right) \quad (\text{EQ. 3})$$

where ΔWin is the Window Width adjustment for material refractive index, and n is the material refractive index, 1.50 for common glass.

The previous steps show that the Window width is 5.11mm - $\Delta \text{Win} = 4.75\text{mm}$ (see Figures 3 and 4).

The unit-to-unit FOV tolerance is dependent on a) the window dimension tolerance, b) the PCB-to-Window tolerance, and c) the Window thickness tolerance. If the tolerance for each of the dependencies is $\pm 0.1\text{mm}$ (typical for plastic injection-molded parts), then the FOV will be $35 \pm 1.3^\circ$.

The symmetry of the FOV (positive half-angle equal to negative half-angle) depends on a) the IC placement accuracy, and b) the PCB alignment tolerance. If the tolerance for each of these also is $\pm 0.1\text{mm}$, then $\Delta \text{FOV} = \text{PHA} \pm \text{NHA}$ (Positive/Negative Half Angle) will be $\pm 3.1^\circ$.

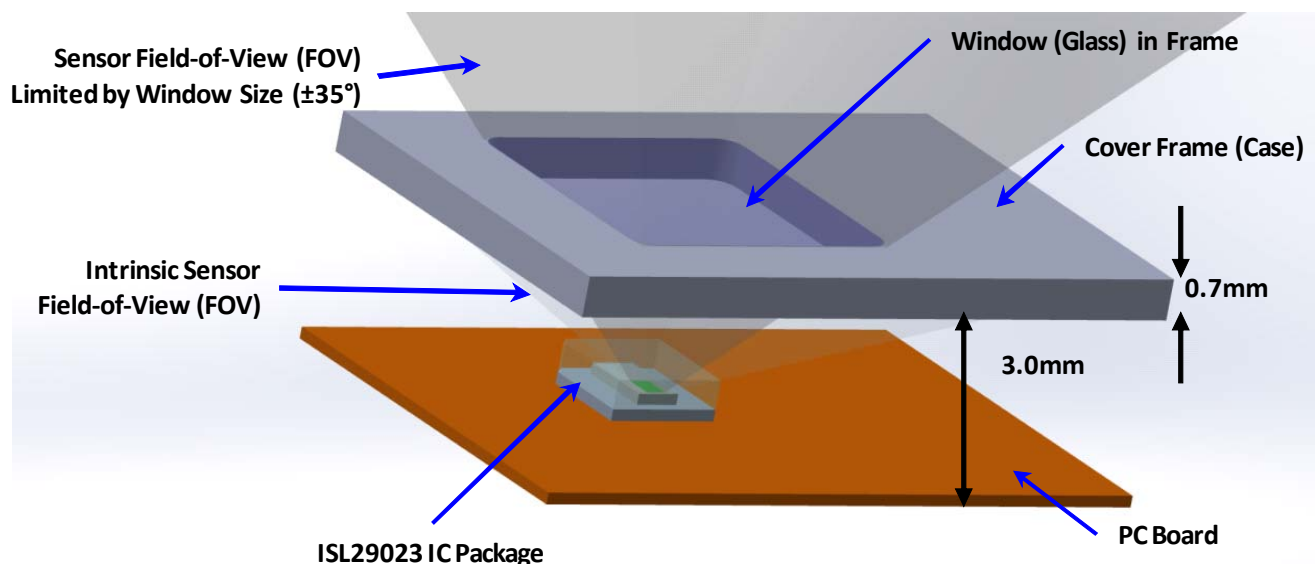

FIGURE 2. ISL29023 OPTO-MECHANICAL REFERENCE MODEL

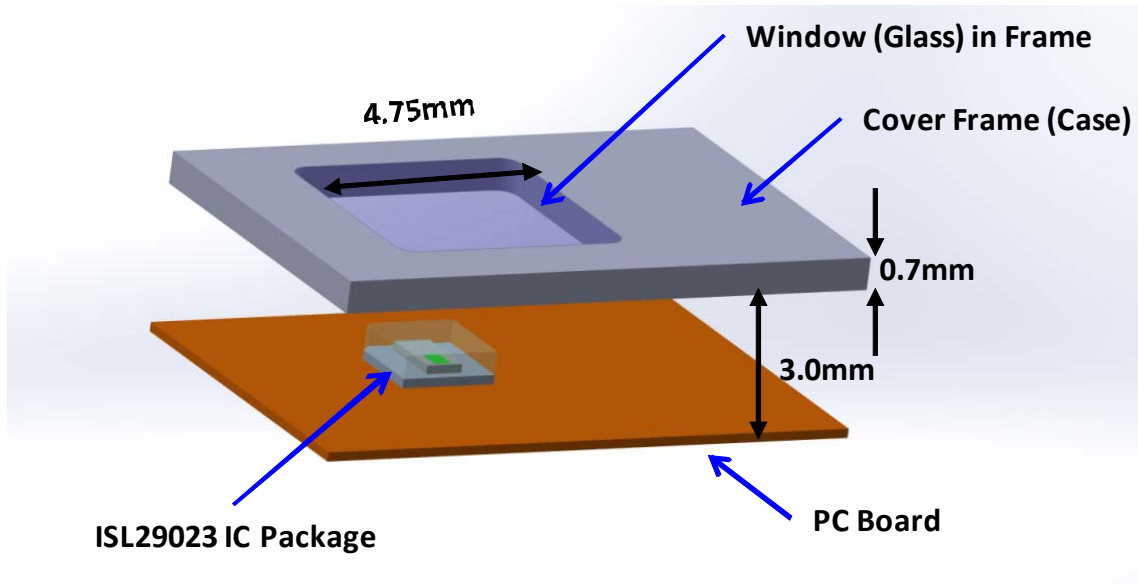

FIGURE 3. REFERENCE MODEL COMPONENTS

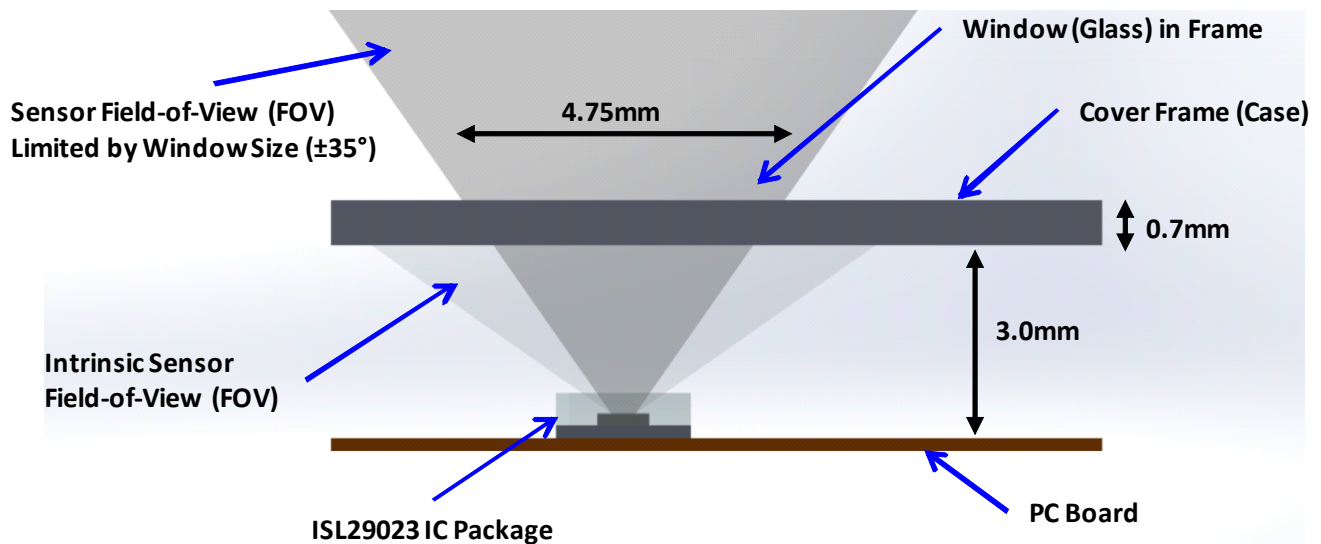

FIGURE 4. REFERENCE MODEL SIDE VIEW

Window Materials

The preceding example highlights an important point: the Window size (or FOV) is dependent on the Refractive Index of the Window and, thus, the Window material. For the example, common glass was used with a refractive index, n , of 1.50. However, not all glass is common and many other materials also may be used - such as many optical plastics. The refractive index varies with material. For typical window glasses, the refractive index varies between 1.43 and 1.55. For optical plastics, the refractive index varies from 1.48 to 1.70. The thicker the Window, the greater the effect of the material refractive index on

the Window size. Table 1 provides the nominal refractive index for many window materials commonly used in mobile devices.

The Abbe Value provided in Table 1 is a measure of the optical dispersion for the material and represents the variation of the material refractive index with wavelength. A higher Abbe Value indicates a smaller index variation with wavelength, dn/d . Dispersion is an important factor for any visible light imaging system. Thus, lenses (or, light pipes) are used since the focal-point (or, Internal Reflection angle) for blue light may be quite different than for red light.

Application Note 1782

TABLE 1. MATERIAL REFRACTIVE INDEX

MATERIAL	INDEX	ABBE VALUE
Soda-Lime Glass	1.52	87.7
Calcium-Fluoride	1.43	94.9
Corning Gorilla Glass	1.50	n/a
Acrylic (PMMA)	1.49	57.2

TABLE 1. MATERIAL REFRACTIVE INDEX (Continued)

MATERIAL	INDEX	ABBE VALUE
Polycarbonate (PC)	1.585	34.0
Polystyrene (PS)	1.59	30.8
Olefin (COC, COP)	1.53	57.0
Polyethyleneimine (PEI)	1.68	19.0

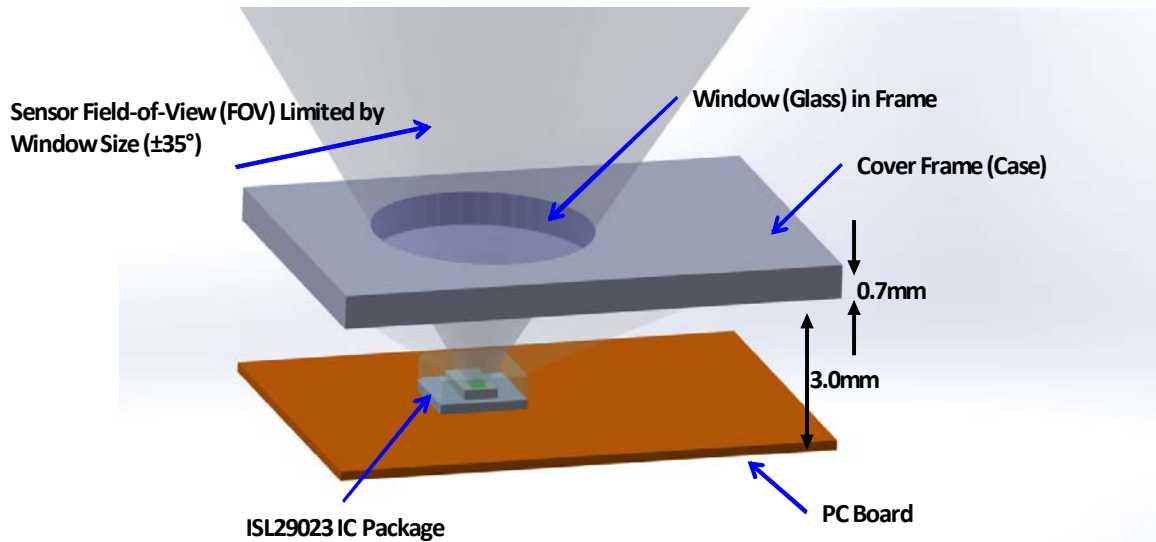

FIGURE 5. THE CIRCULAR APERTURE MODEL

The Circular Aperture Model

Circular, rather than rectangular, apertures often are preferred for windows in mobile devices. Note, much care must be taken when implementing a circular window or aperture (see Figure 5). All silicon photodetectors are fabricated in a square or, rectangular shape. Thus, the rectangular aperture provides much better illumination of the Ambient Light Sensor. A circular aperture may be used, however, it is important that the geometrical circle be circumscribed on the ideal rectangular aperture dimensions. In other words, the diameter of the circular aperture should be no less than the diagonal dimension of the ideal rectangular aperture. This condition is illustrated in Figure 6. The circumscribed circular aperture assures that the full FOV is maintained for all azimuthal angles. Optically, the rectangle aperture is more efficient: it provides greater light collecting ability (larger solid-angle, see Appendix A) with a smaller aperture.

Most Ambient Light Sensor photodetectors are segmented so that several spectral filters may be used to detect different wavelength ranges of visible and infrared ambient illumination.

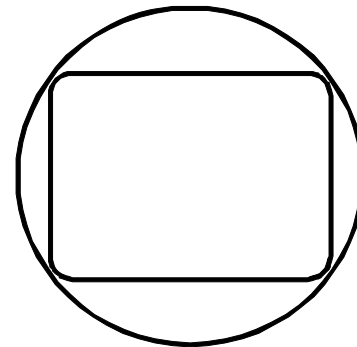

FIGURE 6. CIRCUMSCRIBED CIRCULAR APERTURE

Typically, spectral filtering is used to compensate different types of light sources, such as incandescent (blackbody) and fluorescent (non-blackbody) light sources. Figure 7 shows the spectral filter configuration for the ISL29023. Most visible spectral filters allow some level of infrared (IR) light to reach the photodetector - IR leakage. An IR spectral filter is used to separately detect the IR illumination and correct the IR leakage in the visible filter. Non-blackbody light sources, such as fluorescent lamps and LED sources typically do not emit much IR light. However, blackbody sources such as incandescent and halogen lamps emit much IR light.

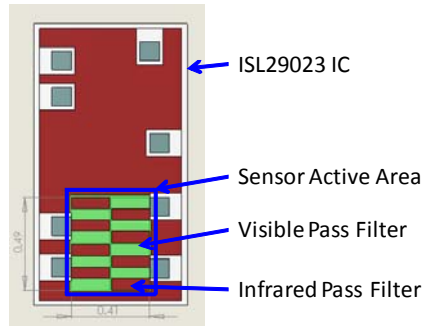

FIGURE 7. ISL29023 SPECTRAL FILTER CONFIGURATION

Sensor Field-of-View (FOV) Limited by Window Size ($\pm 35^\circ$)

Shadowing (Sensor area not illuminated) due to Circular Aperture

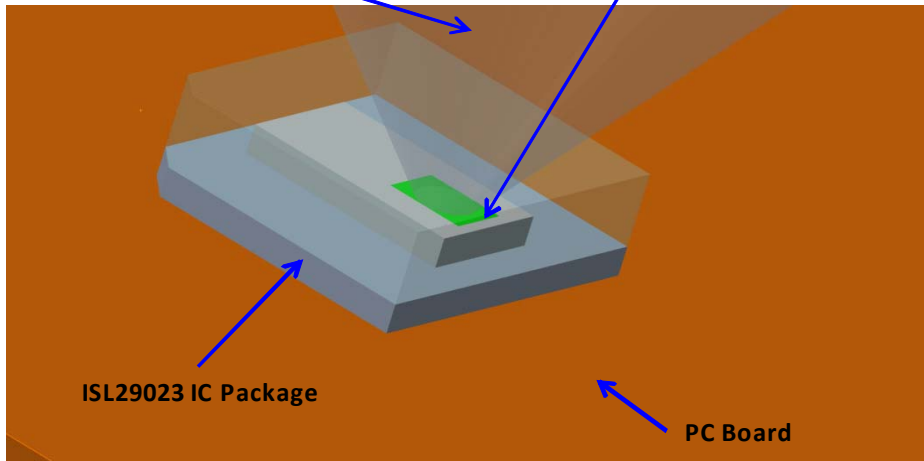

FIGURE 8. LIGHT SENSOR SHADOWING

The performance of the light source compensation (IR leakage correction) depends on uniform illumination of all the spectrally filtered detector segments. If, for example, ambient illumination is prevented (blocked) from reaching the IR-filtered photodetector, then the IR leakage circuits will not be able to properly correct the leakage condition. Figure 8 shows this "shadowing" effect on the photodetector of the ISL29023. The Ambient Light Sensor IC package on a PCB is illuminated through a circular aperture smaller than the recommended rectangular aperture described previously. The ambient illumination underfills the photodetector area. If the ambient light source is small and directional, the shadowing effect may be more pronounced; thus, further reducing the effectiveness of the IR leakage correction. Reducing the diameter of the circular aperture reduces the effective FOV and increases the probability of sensor shadowing.

Hard Aperture vs Soft Aperture

Up to this point, the reference model only has considered an insert Window in a physical aperture (opening) within the case or, frame, of the mobile product. However, another configuration frequently is implemented in mobile products. In this case, a large-area cover glass plate is used and the aperture is formed by

an opening in a printed ink layer on the inside surface of the glass plate. The ink layer is opaque to visible and IR light - thus blocking all illumination from certain directions. Typically, the aperture area also is covered by a printed ink. However, this ink allows some of the visible - and infrared - illumination to pass on to the Ambient Light Sensor. Typically, 5% to 10% of the incident visible illumination is transmitted by the aperture ink layer.

Aperture size determination is different for the case of a printed ink aperture than for the "hard," physical aperture described above. In this case, the aperture is limited to the inside surface of the glass plate and, effectively, has zero thickness. Figure 9 shows a detailed, scale drawing for the "hard" aperture configuration and Figure 10 shows the scale drawing for the "soft" aperture case.

All mechanical dimensions from the previous discussion on aperture size determination are retained in these figures. All mechanical dimensions in these two figures are the same: the PCB to Window distance, the Window (glass plate) thickness, the Window (glass plate) refractive index, and the desired FOV half-angle. The only difference is that Figure 9 shows a Window inset in the mobile device case (frame), forming a physical hard-aperture and Figure 10 shows a large glass plate with the aperture formed by the printed ink layer on the inside surface of

Application Note 1782

the glass plate. Refraction of the incident ambient light still occurs at the glass plate surfaces, just as with the hard aperture Window.

The desired FOV is the same in both cases. However, in the hard aperture case, the limiting aperture for the FOV is at the top (outside) surface of the Window (case, frame). While for the soft aperture case, the limiting aperture for the FOV is at the bottom (inside) surface of the glass plate. Locating the limiting aperture on inside surface of the glass plate reduces the required aperture dimensions shown by Equation 4.

$$2 \cdot t_w \cdot \tan(\text{FOV} \cdot \text{Half} \cdot \text{Angle}) \quad (\text{EQ. 4})$$

where t_w is the thickness of the glass plate (window) - from 4.75mm to 4.18mm, as shown in Figures 9 and 10.

With the printed ink aperture, the determination of the aperture dimensions is somewhat simplified compared to the earlier analysis for the "Hard Aperture" case discussed on page 5.

1. Select the PCB-to-Window separation distance (3.0mm) as shown in Figure 10.
2. Select the desired Field-of-View for the Ambient Light Sensor to $\pm 35^\circ$ in this example.
3. The Aperture-to-Sensor distance is simply:

$$T = \text{Gap} - s_v \quad (\text{EQ. 5})$$

where Gap is the PCB-to-Window Distance, 3.0mm, and s_v is the vertical sensor location relative to the ISL29023 IC package, 0.4mm.

4. Calculate the Window dimension as shown by Equation 6 :

$$W_{in} = 2 \cdot T \cdot \tan 35^\circ + s_w \quad (\text{EQ. 6})$$

T is the Aperture-to-Sensor distance, and s_w is the ISL29023 sensor width, 0.44mm.

The adjustment for the Window (glass plate) material Refractive Index is not required for this case.

The previous steps show the Window width is 4.13mm as in Figure 10.

Since the tolerance dependencies for the FOV are reduced for the soft aperture case - the Window (glass plate) thickness is eliminated - the unit-to-unit FOV tolerance also is reduced. Assuming the tolerance for each of the dependencies remains $\pm 0.1\text{mm}$, then the FOV will be $35 \pm 1.23^\circ$. The positional tolerances effect on FOV asymmetry will remain unchanged from the hard aperture case.

Appendix A: Solid-Angle Geometry

Throughout this Application Note, FOV has been discussed in terms plane angles, particularly the FOV planar half-angle. However, in 3-dimensional space, FOV also is a 3-dimensional entity or, solid-angle, in units of steradians, sr, rather than degrees or radians. A conical solid-angle is expressed by Equation 7.

$$\Omega = \frac{a}{r^2} \quad (\text{EQ. 7})$$

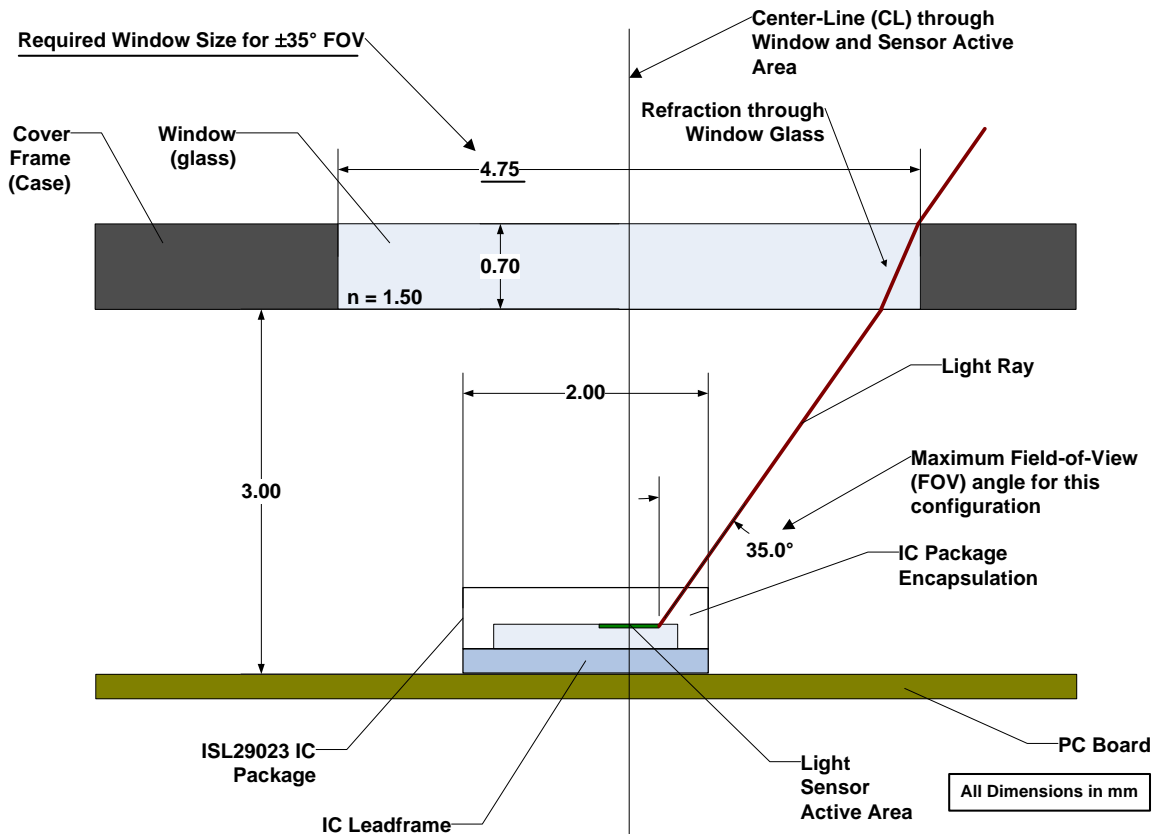

FIGURE 9. HARD APERTURE DETAILED DRAWING

Application Note 1782

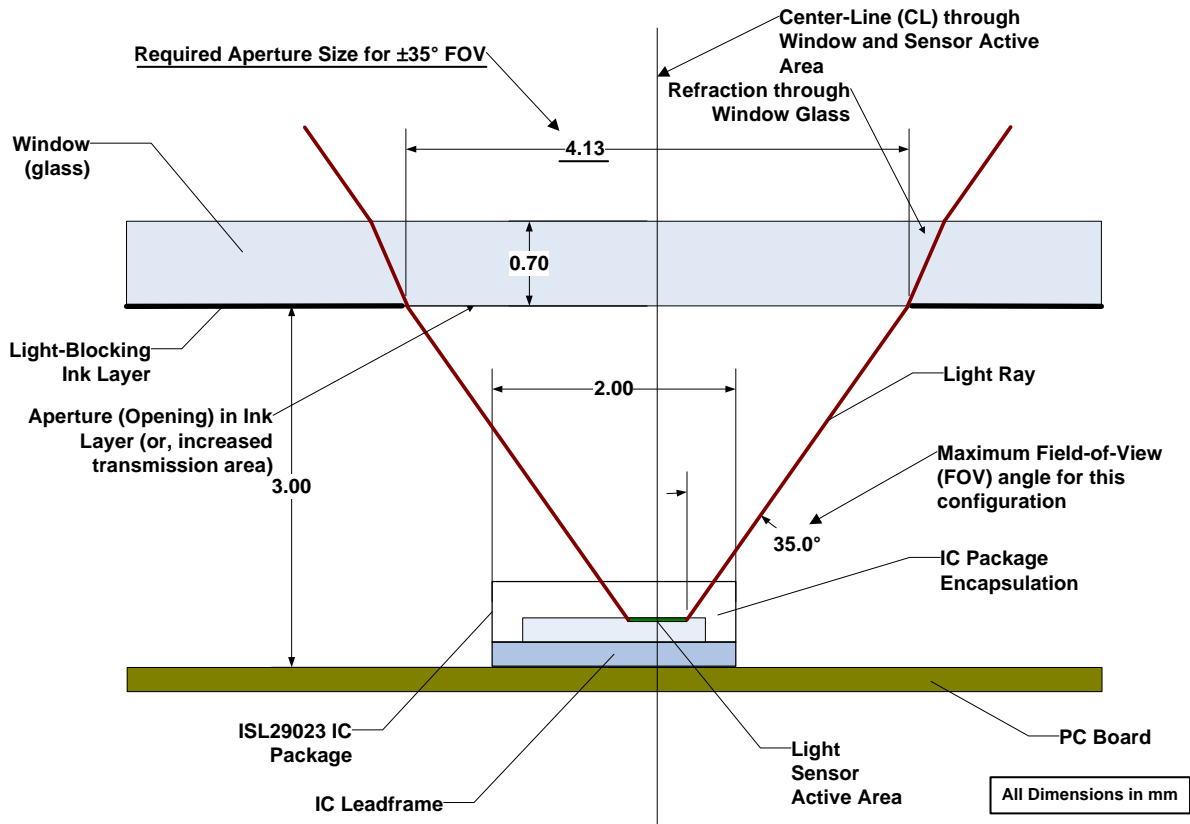

FIGURE 10. SOFT APERTURE DETAILED DRAWING

where Ω is the solid-angle, a is the area subtended by the solid-angle on a spherical surface, and r is the radial distance from the vertex of the solid-angle to spherical surface, as shown in Figure 11. The frequent reference to the "half-angle" of the FOV has not been arbitrary. The conical solid-angle, Ω , can be calculated directly from the planar half-angle:

$$\Omega = 4\pi \sin^2 \frac{1}{2} \theta_{1/2} \quad (\text{EQ. 8})$$

where Ω is the solid-angle, and $\theta_{1/2}$ is the planer half-angle in radians. So, in the previous examples, the 35° half-angle represents a solid-angle of 1.14 sr. (see Figure 10).

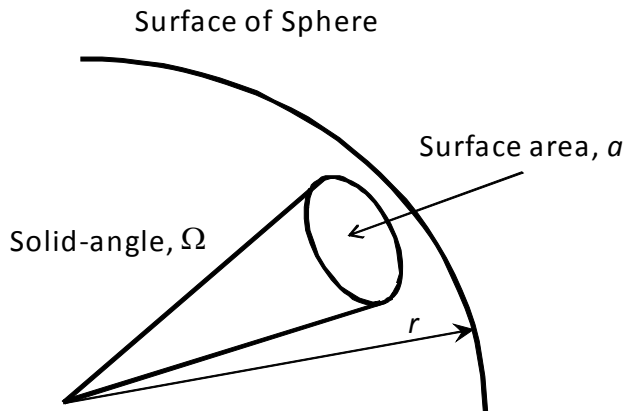

FIGURE 11. SOLID-ANGLE

In the earlier discussion, a rectangular detector area generally provides a rectangular FOV, such as with the ISL29023. The general form for the rectangular Solid-Angle is shown in Figure 12. In this case, surface area, a , is a rectangular section of the surface of the sphere with radius, r . The apex angles, a and b , subtend the vertical and horizontal sides of surface area, a . If surface area, a , is square, then apex angles $a = b$. Apex angle, $a = 2 \times \theta_{1/2}$, and apex angle, $b = 2 \times \phi_{1/2}$. The solid-angle is expressed by Equation 9.

$$\Omega = 4 \cdot \text{asin} \left(\sin \frac{a}{2} \sin \frac{b}{2} \right) \quad (\text{EQ. 9})$$

or by Equation 10.

$$\Omega = 4 \cdot \text{asin} (\sin \theta_{1/2} \sin \phi_{1/2}) \quad (\text{EQ. 10})$$

Thus, in the previous examples, the 35° half-angle rectangular solid-angle is $\Omega = 1.34$ sr.

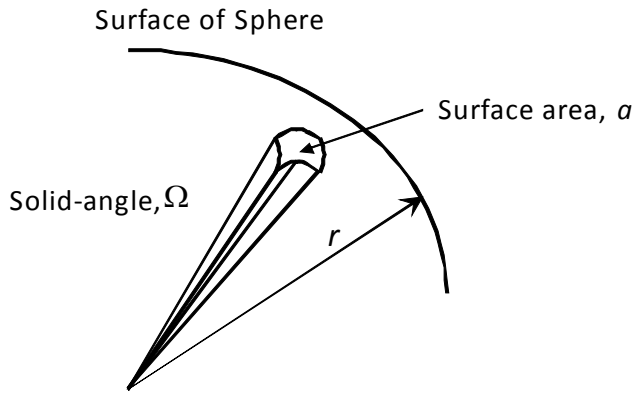

FIGURE 12. RECTANGULAR SOLID-ANGLE

Appendix B: Radiometry and Photometry

Any application of ambient light sensors (and, frequently, proximity sensors) involves radiometry and photometry and their respective units of measure. Unfortunately, in these applications, radiometry and photometry often are intermingled, which is confusing to someone not familiar with the terminology.

While this appendix, by no means, intends to fully resolve the complexity of these fields, it should provide the most basic concepts and a very brief description of the respective units of measure and their duality.

TABLE 2. RADIOMETRIC UNITS

QUANTITY	SYMBOL	DEFINITION	UNIT
Radiant Energy	Q	$\int \Phi dt$	J
Radiant Energy Density	U	dQ/dV	J/m^3
Radiant Flux (power)	Φ, P	dQ/dt	W
Radiant Exitance	M	$d\Phi/dA$	W/m^2
Irradiance	E	$d\Phi/dA$	W/m^2
Radiance	L	$d^2\Phi/dA_{proj}d\Omega$	W/m^2sr
Radiant Intensity	I	$d\Phi/d\Omega$	W/sr

Radiometry deals with the measurement of general optical radiation fields over a wide range of wavelengths, from the extreme ultraviolet (EUV) to the far infrared (FIR), including the radiative transference of heat energy. The basic SI units of optical radiant energy and radiant flux (power) are the joule and the watt. Table 2 lists the basic units of Radiometry and their relationships.

In the table, A is the area of either a radiant source or receiver (detector), Ω is the solid-angle (see Appendix A), and A_{proj} is the projected area per unit solid-angle leaving a radiant source or,

any reference surface, defined by $dA_{proj} = dA \cos \theta$, where θ is the projection angle.

The first three quantities in Table 2 are self-explanatory. The remaining four quantities require a brief explanation. Radiant Exitance, Radiance, and Radiant Intensity describe optical radiation leaving a radiant source or, some arbitrary surface. Irradiance describes optical radiation encountering a surface or, receiver such as a sensor. Typically, light sources are described by Total Radiant Flux (in all directions), Radiance (in a particular direction), or Radiant Intensity (relative to a reference solid-angle). Light receivers are described by Irradiance relative to the area of the receiver.

Photometry, on the other hand, deals with the measurement of the transference of Visible light through optical systems. Unlike radiometry, photometry only is concerned with that portion of the radiation field that can induce a visual response. The basic SI unit of Luminous Intensity is the candela (cd). Table 3 lists the basic units of Photometry and their relationships.

TABLE 3. PHOTOMETRIC UNITS

QUANTITY	SYMBOL	DEFINITION	UNIT
Luminous Energy	Q_v	$\int \Phi_v dt$	lm-s = talbot
Luminous Density	U_v	dQ_v/dV	$lm-s/m^3$
Luminous Flux	Φ_v	dQ_v/dt	lm
Illuminance	E_v	$d\Phi_v/dA$	$lm/m^2 = lx$
Luminous Exitance	M_v	$d\Phi_v/dA$	$lm/m^2 = lx$
Luminance	L_v	$d^2\Phi_v/dA_{proj}d\Omega$	$lm/m^2sr = nt$
Luminous Intensity	I_v	$d\Phi_v/d\Omega$	$lm/sr = cd$

Tables 2 and 3 show that every photometric quantity is the dual of a radiometric quantity and is defined by the same geometric relationship. From the SI base unit, candela, the unit of Luminous Flux, the lumen (lm) is derived. From the lumen, the remaining units are derived: the talbot (T), lux (lx), and nit (nt). As with radiometric quantities, Luminous Exitance, Intensity, and Luminance describe visible light energy leaving a luminous source or, a reference surface, and Illuminance describes the visible light energy incident on a receiver or, surface.

Photometric units are related to radiometric units through the standard Photopic Response, or Luminosity Function, based on the visual response of the human eye shown by Equation 11.

$$F = 683 \frac{lm}{W} \int_0^{\infty} \bar{y}(\lambda) J(\lambda) d\lambda \quad (EQ. 11)$$

Where F is the luminous flux in lumens, $J(\lambda)$ is the spectral power distribution (power per unit wavelength, in W/m), $\bar{y}(\lambda)$ is standard luminosity function (dimensionless), and λ is wavelength in meters. Typically, the standard luminosity function is normalized to 683 lm/W at 555nm.

Bibliography

Datasheets

ISL29023: Integrated Digital Light Sensor with Interrupt, 2012, Intersil, Corp.,

<http://www.intersil.com/content/dam/Intersil/documents/fn66/fn6691.pdf>

Technical References

Radiometry and the Detection of Optical Radiation, Robert W. Boyd, 1983, John Wiley & Sons, Inc.

The Art of Radiometry, James M. Palmer and Barbara G. Grant, 2010, Society of Photo-Optical Instrumentation Engineers (SPIE).

"Photometry (Optics),"

[http://en.wikipedia.org/wiki/Photometry_\(optics\)](http://en.wikipedia.org/wiki/Photometry_(optics)).

Author

Allen M. Earman

Principal Optical Applications Engineer

Intersil Corp.

1001 Murphy Ranch Road
Milpitas, California, USA, 95035

Intersil Corporation reserves the right to make changes in circuit design, software and/or specifications at any time without notice. Accordingly, the reader is cautioned to verify that the Application Note or Technical Brief is current before proceeding.

For information regarding Intersil Corporation and its products, see www.intersil.com
